

TRANSMISSION SWITCH KIT

4 x 4 700-R4 to 400 Pickup Truck

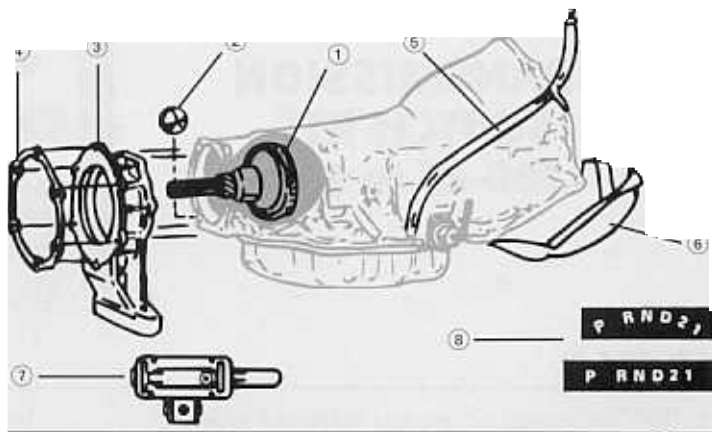

7-40A

1. Install output shaft (Item #1) in a 400 Chevy transmission at the time of rebuilding.
2. The freeze plug (Item #2) is to be driven, hollow side out, into the transmission case where the speedometer housing has been removed.
3. The adapter block (Item #3) should be bolted with the six hex head bolts, furnished in the kit, to the rear of the transmission case. Be sure to use the extension housing gasket furnished with the 400 rebuilding kit. The transfer case now is ready to install. The transfer case gasket (Item #4) is furnished in the kit.
4. Install the 400 rebuilt unit with a 350 non Lock-up converter. To use a 400 converter (three lug or six lug), the flywheel will have to be changed if the flywheel does not have dual bolt pattern.
5. Install the filler tube with stick (Item #5) and the dust cover (Item #6). The filler tube in this kit is for a shallow pan, but it also will work on a deep pan.
6. The passing gear switch (Item #7) is mounted on the accelerator bracket in such a way that the movement of the accelerator pedal will move the bar on the switch. All trucks have a pre-drilled hole and recessed area to hold this switch. The installer then must run a hot wire to either side of the switch. Another wire must be attached to the remaining lead on the switch and run down to the passing gear connector on the left rear of the transmission.
7. The plastic indicator decal (Item #8) is installed by removing the screws that hold the dash into the cowl frame. The indicator plate will be visible. Wipe the indicator clean with alcohol or thinner! Use the right edge and the bottom of the decal as a guide. Peel off the back of the decal and press it firmly on the clean indicator, reassemble dash.

8a. GAS ENGINE: To furnish vacuum to the transmission, use 3/16" tubing (brakeline or equivalent), approximately 3 feet in length. Hook this line into a vacuum source at the engine intake manifold and run down to the modulator.
NOTE: Do not use rubber vacuum tube from motor to transmission. It may heat up and collapse.

8b. DIESEL ENGINE: Remove the Throttle Position Sensor located on the injector pump. Replace this sensor with the transmission regulator GM Part #14057219. Tap into a vacuum line running from the vacuum pump and connect it to the vacuum regulator lower outlet, the one without the red cap. Remove the EGR vacuum line at the intake throat and plug it. It will be necessary to run a vacuum line from the vacuum regulator upper outlet, the one with the red cap, to the modulator.

8c. If there is not adequate vacuum for the vacuum modulator, the Teckpak 40M Mechanical Modulator can be used with the original detent cable, or use Teckpak Detent Cable K77978.

9. After completing installation, take the truck for a test drive. It may be necessary to adjust the shift pattern by adjusting either the vacuum regulator (diesel only) or the modulator, or possibly both.

The selector can be adjusted from under the truck by loosening the adjustment on the linkage coming down from the firewall.

NOTE: This Kit uses "L" type cross-member. Adapter block is 11" long.

Part Number	Length of Shaft
7-40A	7 1/4"